



## INSTALLATION INSTRUCTIONS FOR PART 99-5807

### APPLICATIONS

#### FORD

Edge	2007-2008
Expedition	2007-2008
Explorer	2005-2009
F-150	2004-2008
Five-Hundred	2005-2007
Freestyle	2005-2007
Mustang	2005-2009
Sport Trac	2006-2010
Taurus/Taurus X	2008-2009

#### LINCOLN

Mark LT	2004-2008
---------	-----------

#### MERCURY

Montego	2005-2007
Mountaineer	2005-2010
Sable	2008-2009

# 99-5807

#### KIT FEATURES

- DIN Mount Radio Provision with Pocket
- ISO Mount Radio Provision with Pocket
- Double DIN Mount Radio Provision
- Stacked ISO Units Provision



#### KIT COMPONENTS

- A) Radio Housing (single DIN w/ pocket)
- B) Radio Housing (double DIN / stacked ISO DIN)
- C) Double DIN Brackets
- D) ISO Brackets
- E) Trim Plate

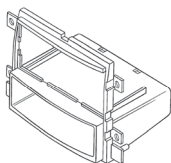
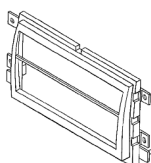
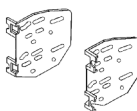
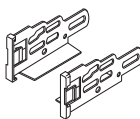
**A****B****C****D****E**

#### WIRING AND ANTENNA CONNECTIONS (Sold Separately)

##### Harness:

- 70-5520 - Ford Harness 2003-up
- 70-5521 - Ford Amplified Harness 2003-up
- 70-5522 - Ford Sub Harness 2003-up
- XSVI-5520 NAV - Ford Interface 2006-up

##### Antenna Adapter:

- 40-CR10 - Chrysler/GM Antenna Adapter 2002-up

#### TOOLS REQUIRED:

Cutting Tool • Phillips Screwdriver • Socket Set

**1-800-221-0932****www.metraonline.com**

© COPYRIGHT 2004-2009

METRA ELECTRONICS CORPORATION



**TABLE OF CONTENTS**

**Dash Disassembly**

**FORD**

- Edge 2007-2008 ..... 2
- Expedition 2007-2008 ..... 2
- Explorer 2005-2009 ..... 1
- F-150 2004-2008 ..... 2
- Five Hundred 2005-2007 ..... 3
- Freestyle 2005-2007 ..... 4
- Mustang 2005-2009 ..... 5
- Sport Trac 2006-2010 ..... 1
- Taurus 2008-2009 ..... 3
- Taurus X 2008-2009 ..... 4

**Lincoln**

- Mark LT 2004-2008 ..... 2

**Mercury**

- Montego 2005-2007 ..... 3
- Mountaineer 2005-2010 ..... 1
- Sable 2008-2009 ..... 3

**Kit Assembly**

- DIN Mount Radio Provision with Pocket ..... 6
- ISO Mount Radio Provision with Pocket ..... 7
- Double DIN Radio Provision ..... 8
- Stacked ISO Units Provision ..... 9

- **Final Assembly** ..... 10

**\*Note:**

**Refer also to the instructions included with the aftermarket radio.**



**KNOWLEDGE IS POWER**  
 Enhance your installation and fabrication skills by enrolling in the most recognized and respected mobile electronics school in our industry. Log onto [www.installerinstitute.com](http://www.installerinstitute.com) or call 800-354-6782 for more information and take steps toward a better tomorrow.



**Metra recommends MECP certified technicians**

**FORD EXPLORER 2005-2009/SPORT TRAC 2006-2010**  
**MERCURY MOUNTAINEER 2005-2010**

- 1** Disconnect the negative battery terminal to prevent an accidental short circuit.
- 2** Open center console and remove (2) Phillips screws then unclip and remove entire panel surrounding shifter. (Figure A)
- 3** Remove dash panel surrounding radio to access the factory radio screws. (Figure B)
- 4** Remove (4) 9/32" screws to remove the factory radio. (Figure C)

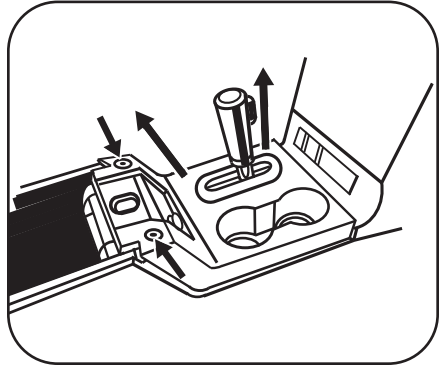
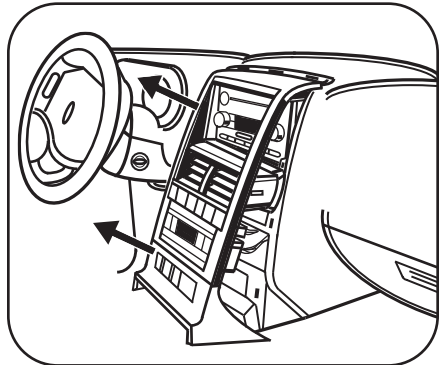
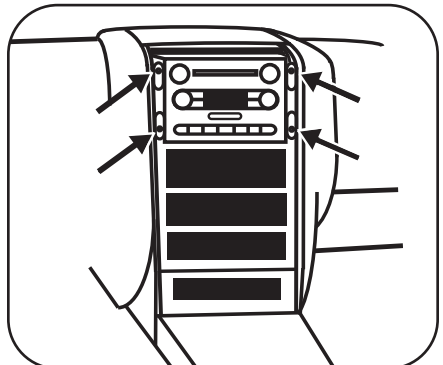
**A**

**B**

**C**

**FORD EDGE/EXPEDITION 2007-2008/F-150 2004-2008  
 LINCOLN MARK LT 2004-2008**

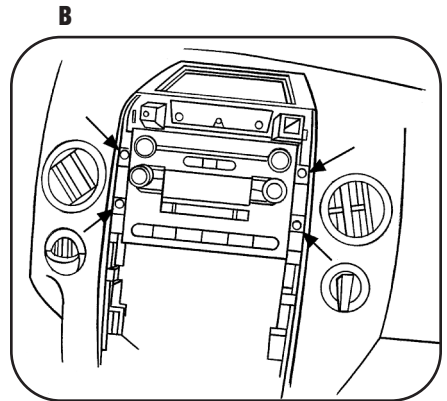
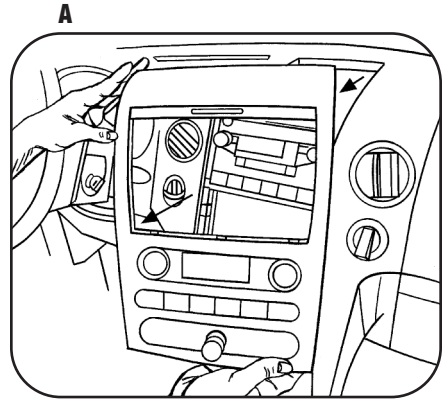
- 1** Disconnect the negative battery terminal to prevent an accidental short circuit.
- 2** Unsnap and remove entire panel surrounding the radio and climate controls. (Figure A)
- 3** Remove (4) 9/32" screws to remove the factory radio. (Figure B)

*Continue to kit assembly.*



**FORD FIVE HUNDRED 2005-2007/TAURUS 2008-09  
 MERCURY MONTEGO 2005-2007/SABLE 2008-09**

- 1 Disconnect the negative battery terminal to prevent an accidental short circuit.
- 2 Unclip and remove the small rectangular trim around shift lever. (Figure A)
- 3 Unclip and remove the entire panel (including cup holders) surrounding the shift lever. (Figure B)
- 4 Remove (2) 9/32" screws at the bottom of the center radio/ climate control panel. (Figure C)
- 5 Unclip and remove the center panel. (Figure D)
- 6 Remove (4) 9/32" screws from the radio to remove.

*Continue to kit assembly.*

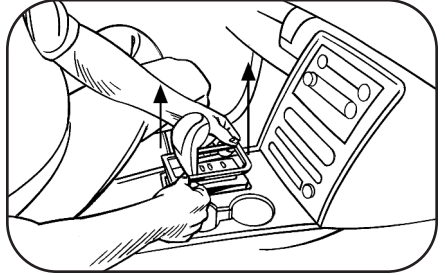
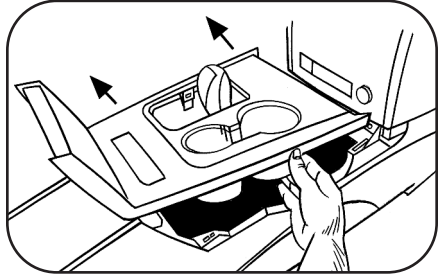
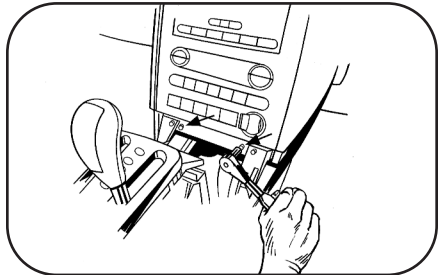
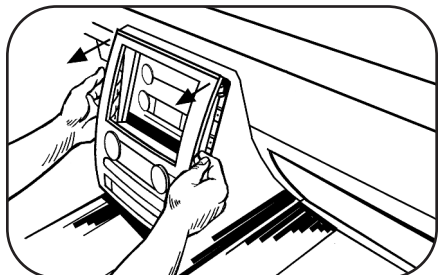
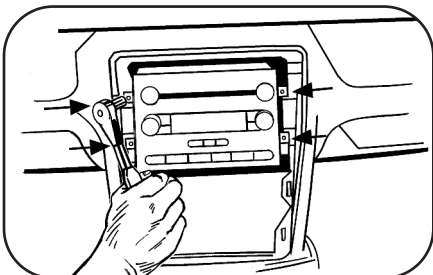
**A**

**B**

**C**

**D**

**E**

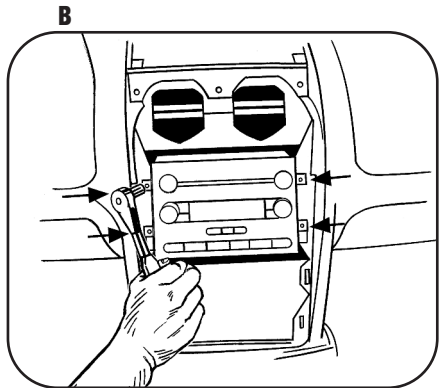
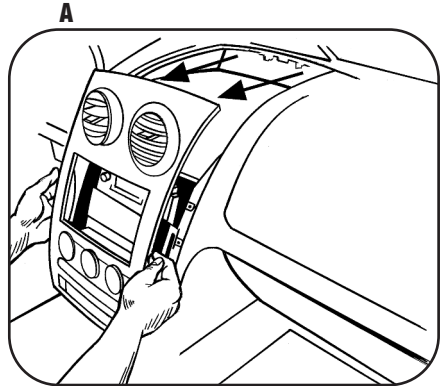
**FORD FIVE HUNDRED 2005-2007/TAURUS 2008-09  
 MERCURY MONTEGO 2005-2007/SABLE 2008-09**

*\*Note: Refer also to the instructions included with the aftermarket radio.*

- 1** Disconnect the negative battery terminal to prevent an accidental short circuit.
- 2** Unclip and remove the entire center panel surrounding the radio and a/c controls. (Figure A)
- 3** Remove (4) 9/32" screws from radio to remove. (Figure B)

*Continue to final assembly.*



**FORD MUSTANG 2005-2009**

- 1** Disconnect the negative battery terminal to prevent an accidental short circuit.
- 2** Remove the small rectangular shifter lever trim panel if equipped. (Figure A)
- 3** Remove (2) Phillips screws from under the center armrest at the back of the shifter trim panel (including cup holders). (Figure B)
- 4** Unclip and remove panel. (Figure B)
- 5** Unclip and remove the (2) center stack trim panels from the left and right side of the radio and climate controls. (Figure C)
- 6** Remove (6) 9/32" screws from center trim panel surrounding the radio and climate controls then unclip and remove panel. (Figure D)
- 7** Unclip and remove panel. (Figure E)

*Continue to kit assembly.*

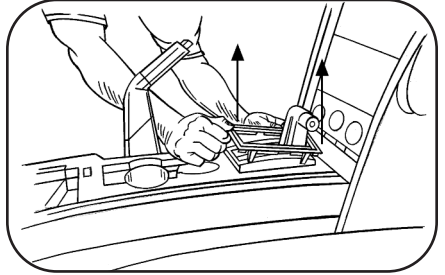
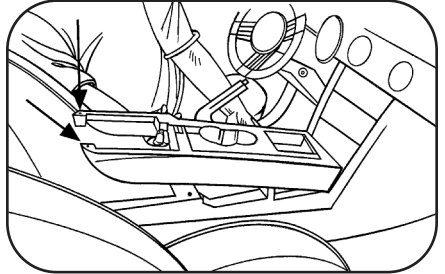
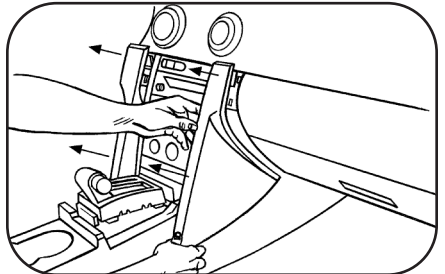
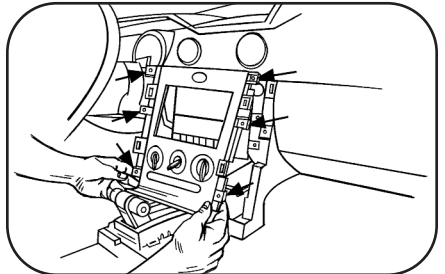
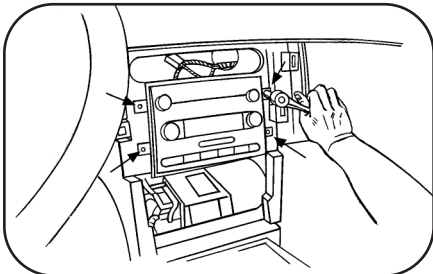
**A**

**B**

**C**

**D**

**E**

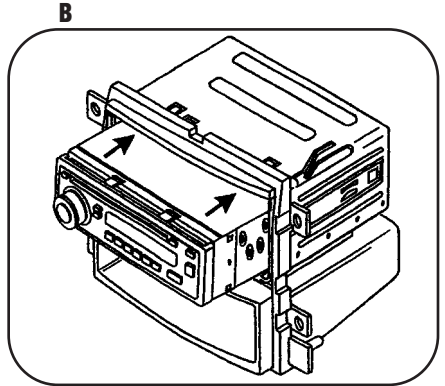
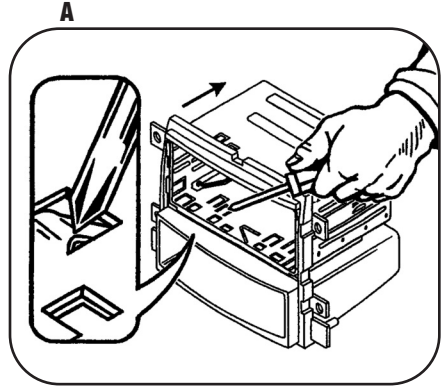
## DIN RADIO PROVISION WITH POCKET

*\*Note: Refer also to the instructions included with the aftermarket radio.*

- 1 Slide the DIN cage into the Radio Housing and secure by bending the metal locking tabs down. (Figure A)
- 2 Slide the aftermarket head unit into the cage and secure. (Figure B)

*Continue to final assembly.*





## ISO RADIO PROVISION WITH POCKET

***\*Note: Refer also to the instructions included with the aftermarket radio.***

- 1 Mount the ISO Brackets to the head unit with the screws supplied with the unit. (Figure A)
- 2 Slide the head unit into the radio opening until the side clips engage. (Figure B)
- 3 Snap the Trim plate into the Radio Housing.

*Continue to final assembly.*

A

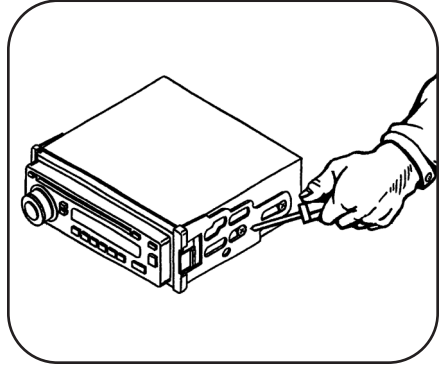

B

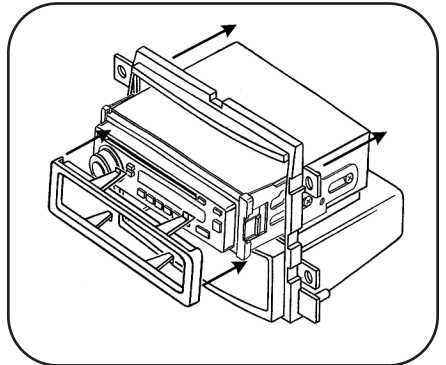

## DOUBLE DIN MOUNT RADIO PROVISION

*\*Note: Refer also to the instructions included with the aftermarket radio.*

- 1 Remove the center bar from the Double DIN trim plate. (Figure A)
- 2 Slide the appropriate side bracket over the mounting legs of the Double DIN trim plate aligning the holes in the trim plate and the bracket. (Figure B)
- 3 Slide the DDIN radio unit into the trim plate bracket assembly and secure the unit to the kit using the screws supplied with the head unit. (Figure C)

**NOTE:**

The notch in the housing should be on top.

*Continue to final assembly.*

**A**

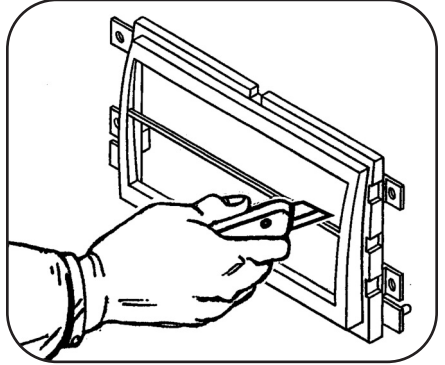

**B**

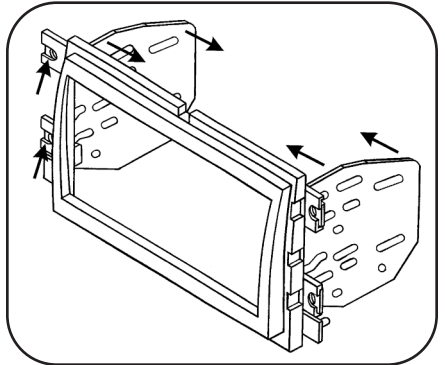

**C**

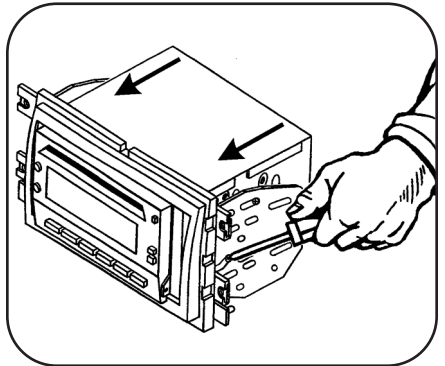

**STACKED ISO UNITS PROVISION**

*\*Note: Refer also to the instructions included with the aftermarket radio.*

- 1 Slide the appropriate side bracket over the mounting legs of the Double DIN trim plate aligning the holes in the trim plate and the bracket. (Figure A)
- 2 Slide the stacked ISO DIN units into the trim plate bracket assembly and secure the units to the kit using the screws supplied with the head units. (Figure B)

**3 NOTE:**

The notch in the housing should be on top.

*Continue to final assembly.*

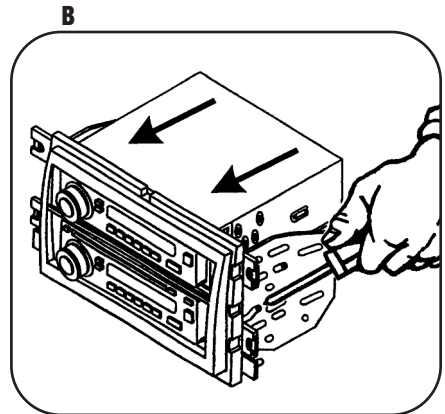
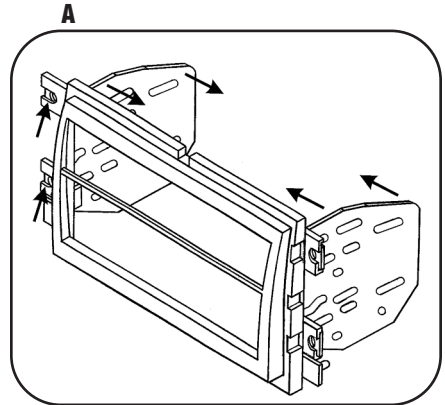

## FINAL ASSEMBLY

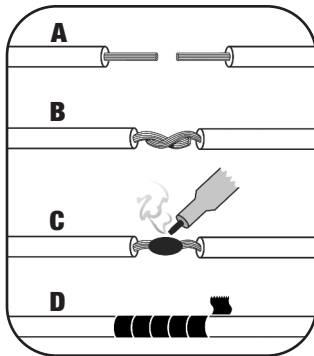

- (A) Strip wire ends back 1/2"**
- B) Twist ends together**
- C) Solder**
- D) Tape**

- 1** Locate the factory wiring harness in the dash. Metra recommends using the proper mating adapter and making connections as shown. (Isolate and individually tape off the ends of any unused wires to prevent electrical short circuit.)
- 2** Re-connect the negative battery terminal and test the unit for proper operation.
- 3** Reassemble radio and dash assemblies in reverse order of disassembly.

### FINAL WIRING CONNECTIONS

Make wiring connections using the EIA color code chart shown below and the instructions included with the head unit. Metra recommends making connections as shown below; Strip, Splice, Solder, Tape. Isolate and individually tape off ends of any unused wires to prevent electrical short circuit.

#### METRA / EIA WIRING CODE

12V Ignition / Acc. . . . .	Red	Right Front (+) . . . . .	Gray
12V Batt / Memory . . . . .	Yellow	Right Front (-) . . . . .	Gray/ Black
Ground . . . . .	Black*	Left Front (+) . . . . .	White
Power Antenna . . . . .	Blue	Left Front (-) . . . . .	White / Black
Amp Turn-On . . . . .	Blue / White	Right Rear (+) . . . . .	Violet
Amp Ground . . . . .	Black / White	Right Rear (-) . . . . .	Violet / Black
Illumination . . . . .	Orange	Left Rear (+) . . . . .	Green
Dimmer . . . . .	Orange / White	Left Rear (-) . . . . .	Green / Black

**\*NOTE:** When a Black wire is not present, ground radio to vehicle chassis.  
All colors may not be present on all leads due to manufacturer's specifications.



**1-800-221-0932**



**www.metraonline.com**